



Robotics

Serial Manipulator Statics

Vladimír Smutný

Center for Machine Perception

Czech Institute for Informatics, Robotics, and Cybernetics (CIIRC)

Czech Technical University in Prague

1

2

3

4

5

6

7

8

9

10

11

12

Statics – Forces and moments acting on the link.



m p

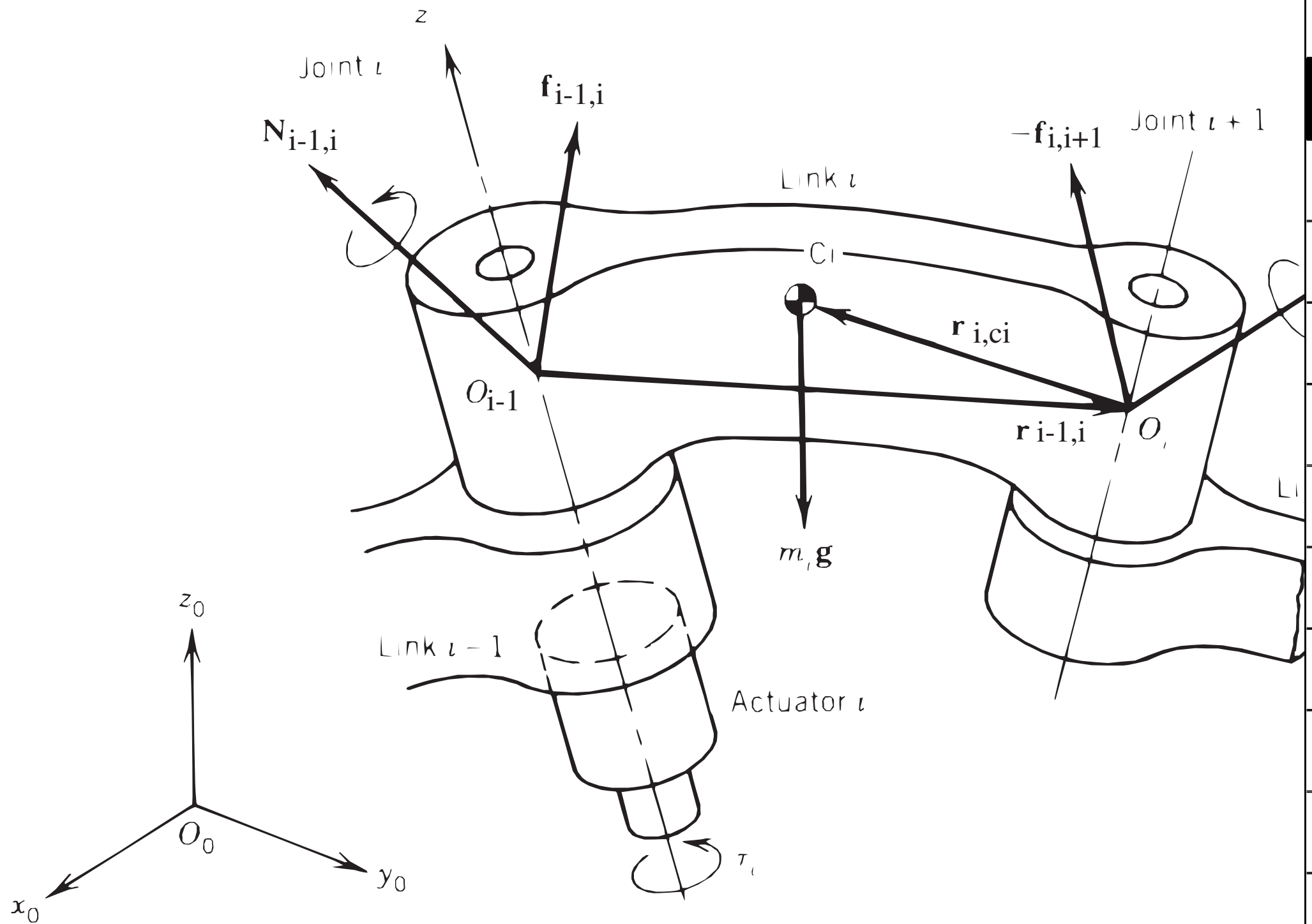

1
2
3
4
5
6
7
8
9
10
11
12

Statics – Forces and moments acting on the link.



m p

1

2

3

4

5

6

7

8

9

10

11

12

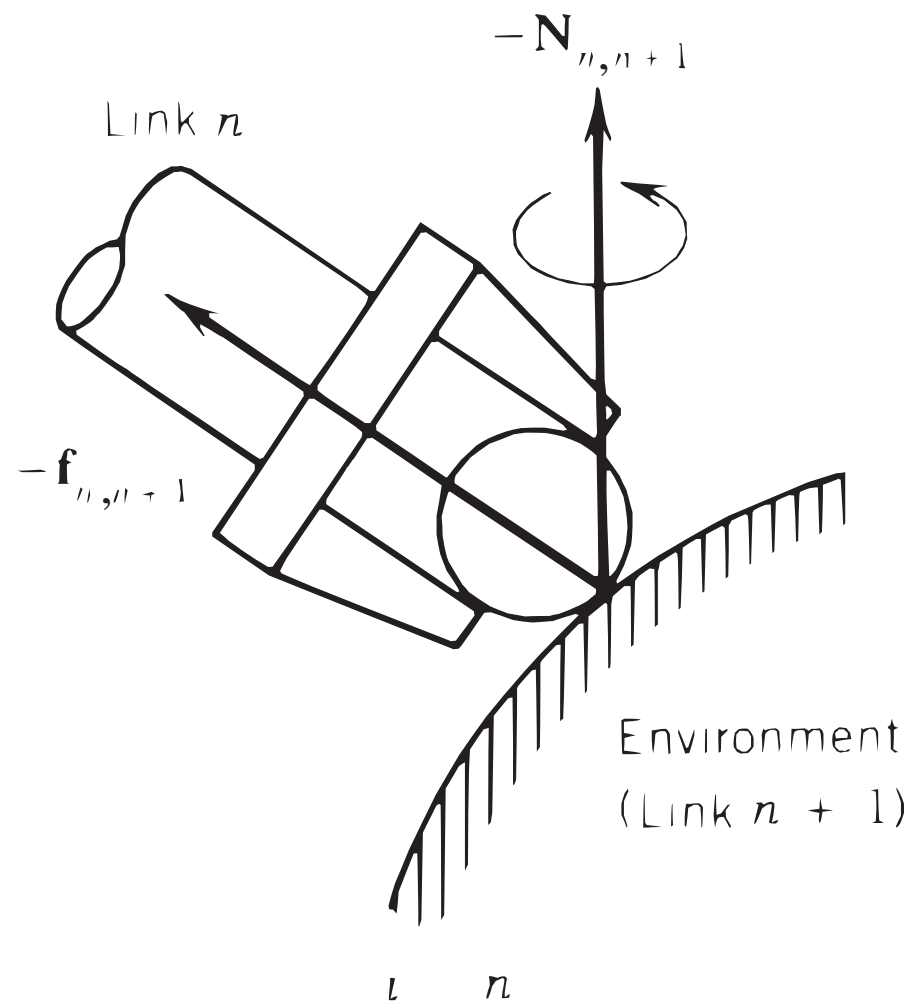
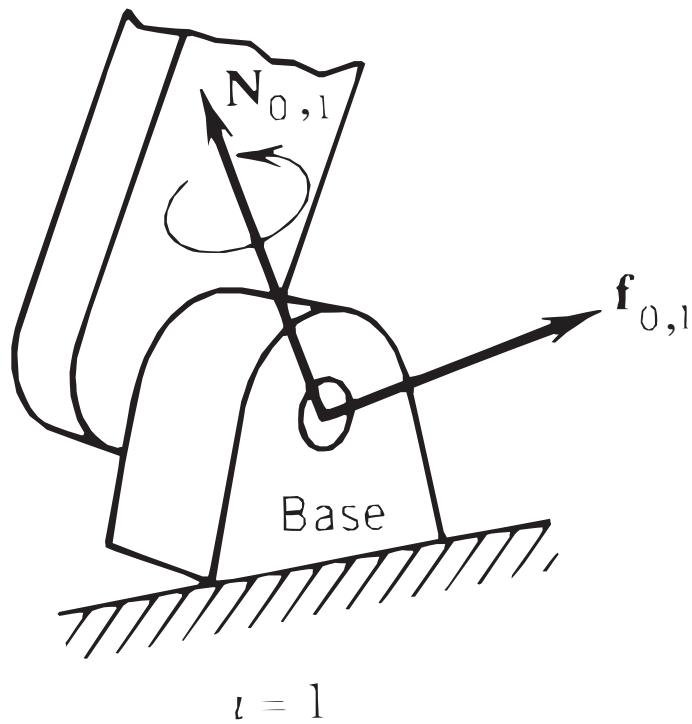

1

2

3

4

5

6

7

8

9

10

11

12

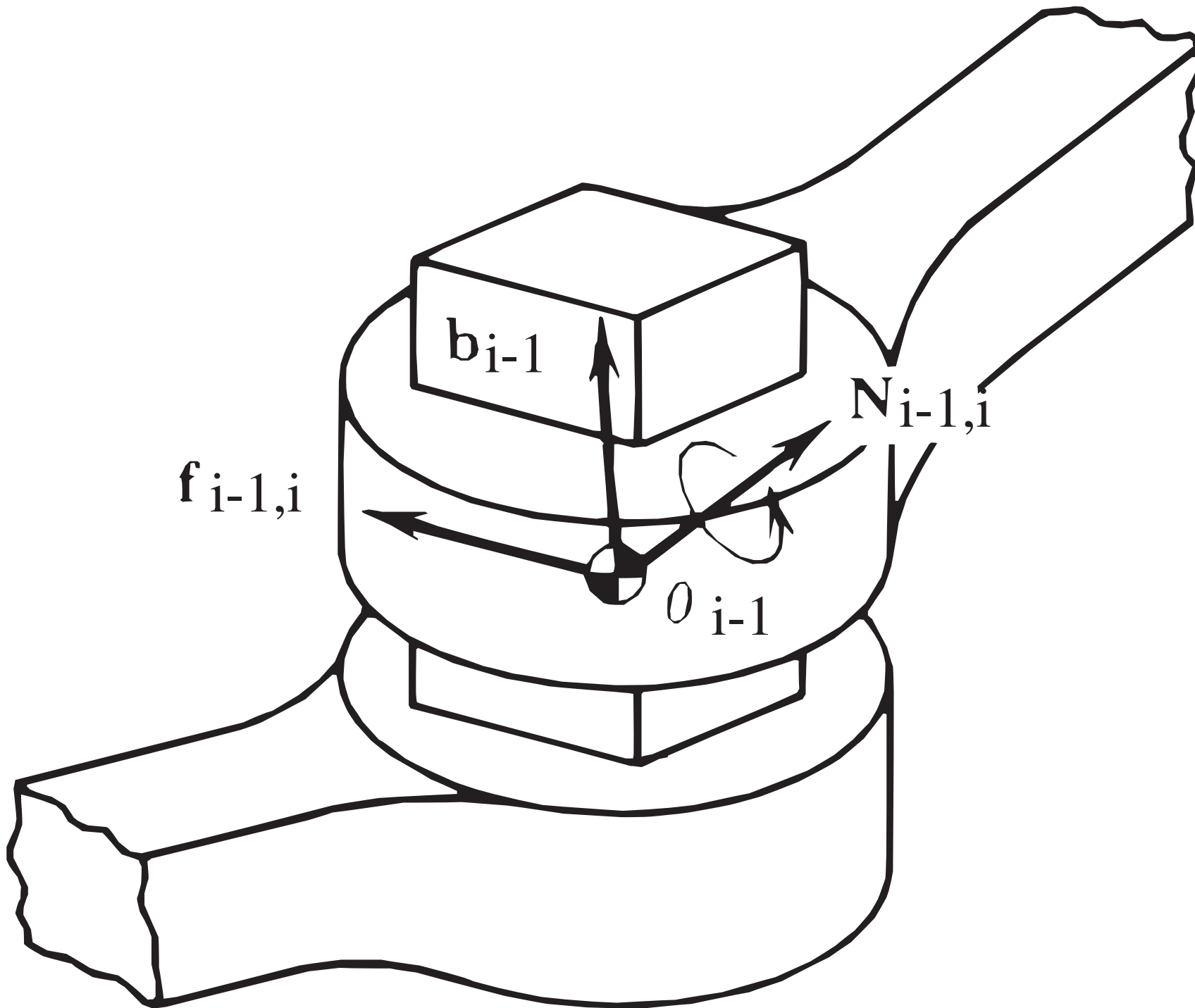

1
2
3
4
5
6
7
8
9
10
11
12

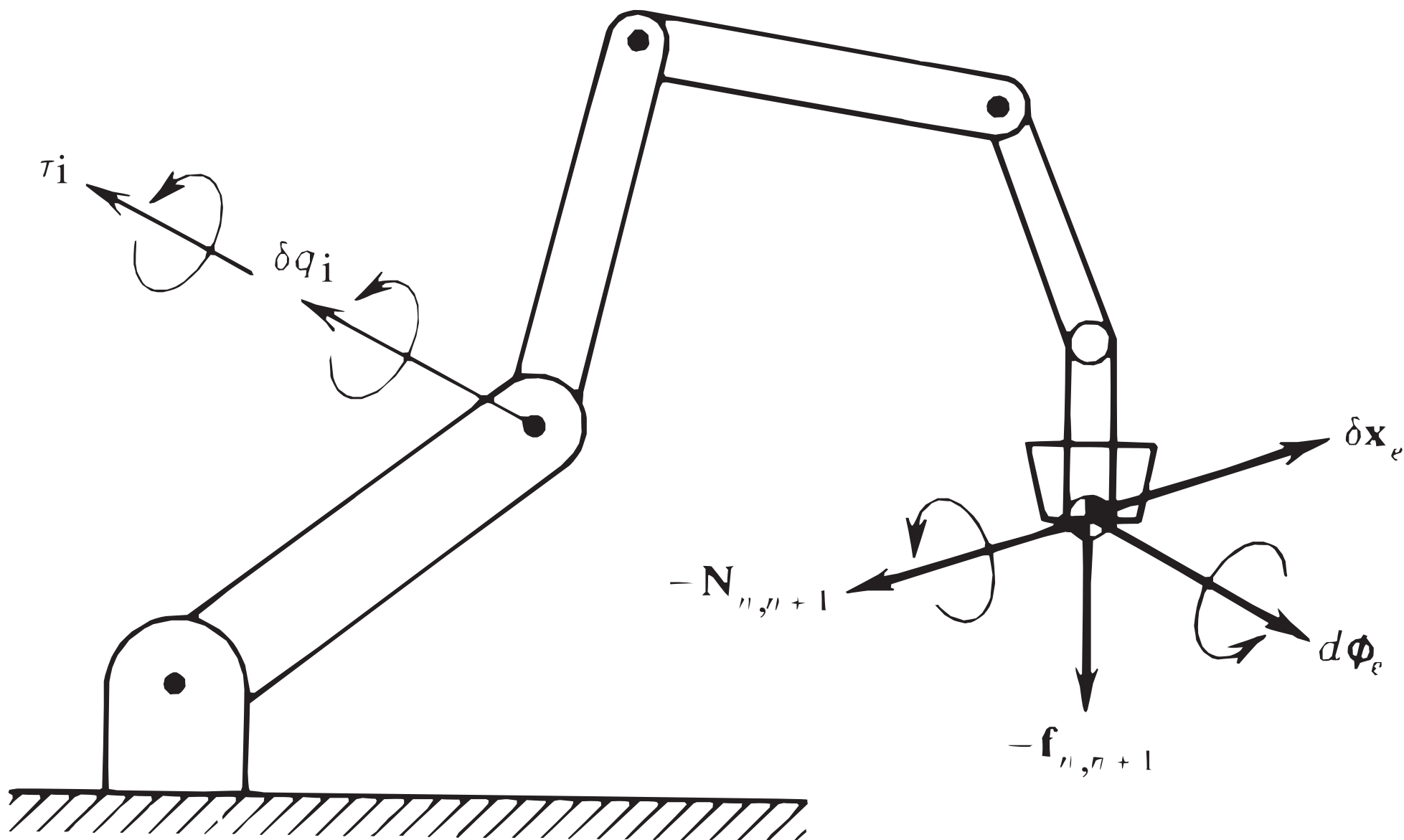

1

2

3

4

5

6

7

8

9

10

11

12

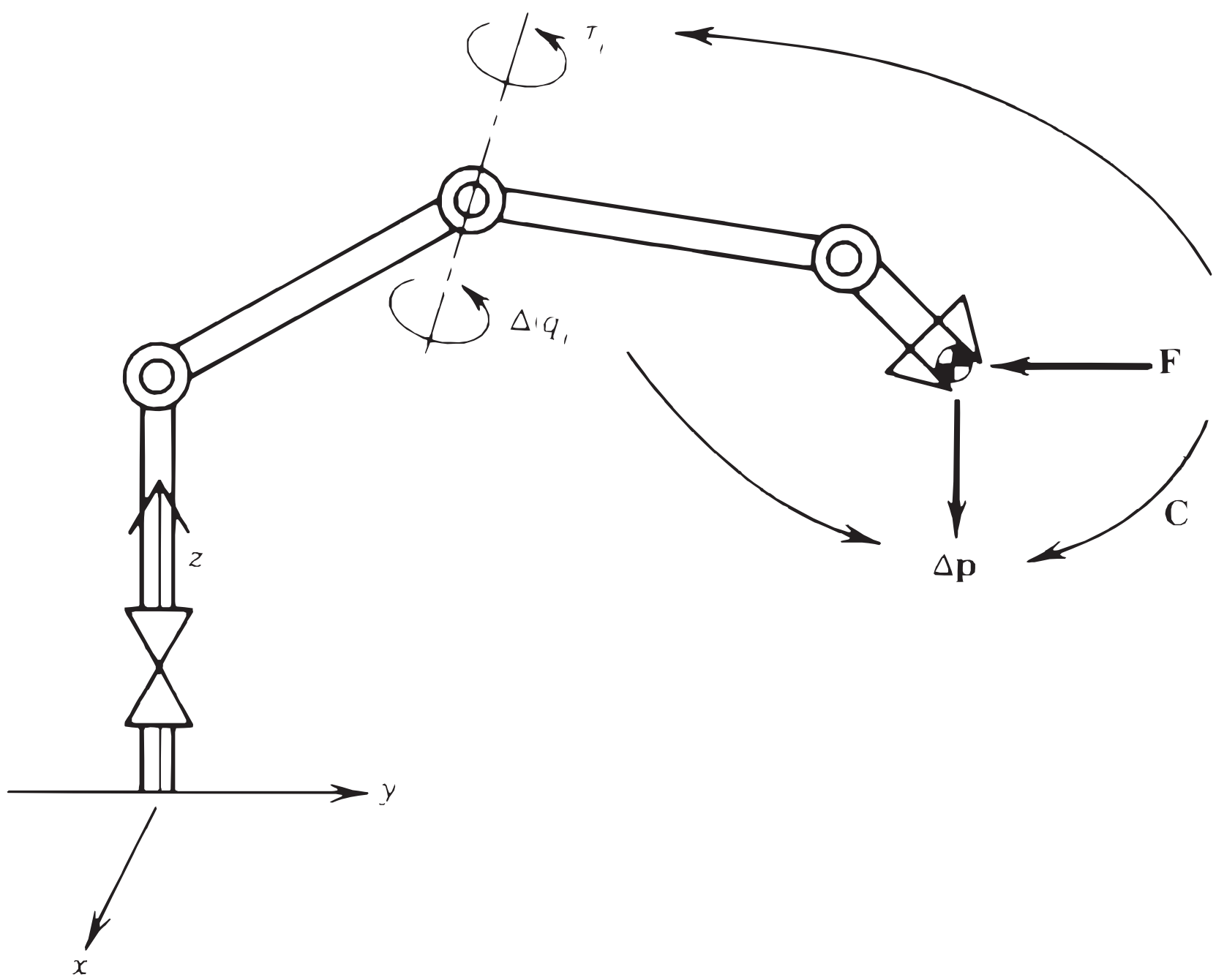

1
2
3
4
5
6
7
8
9
10
11
12

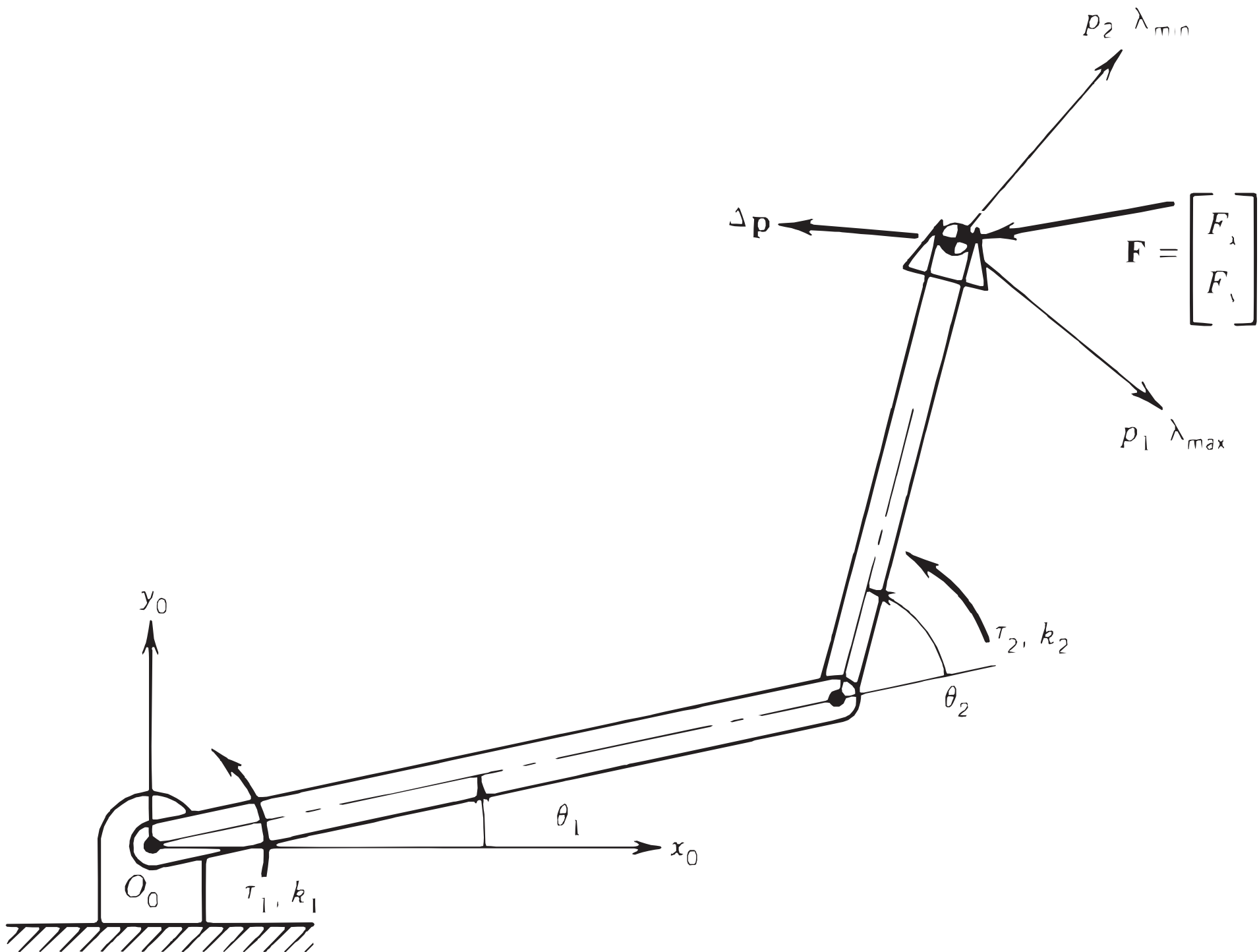

1
2
3
4
5
6
7
8
9
10
11
12

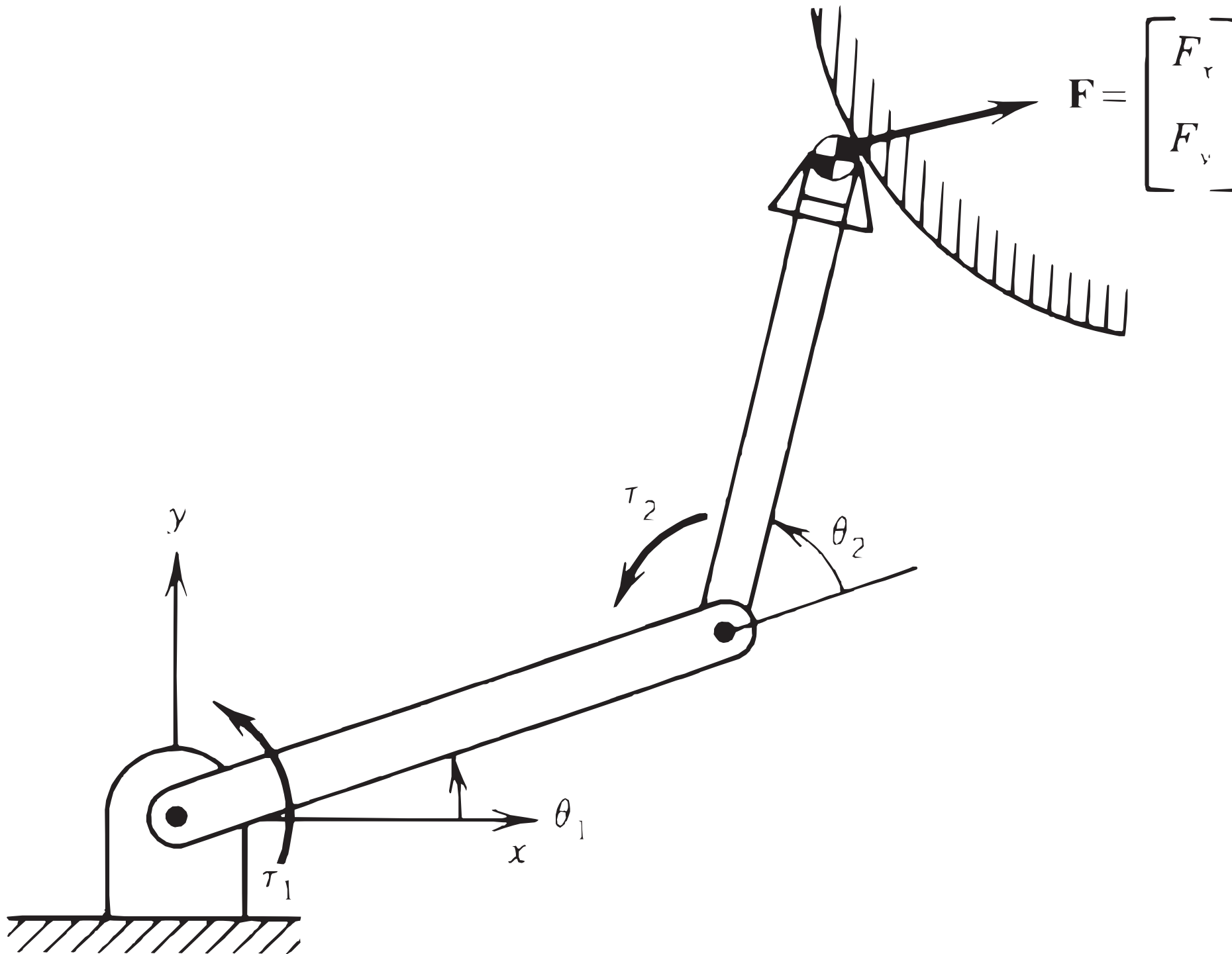

1
2
3
4
5
6
7
8
9
10
11
12

Statics – Mapping for kinematics and statics.

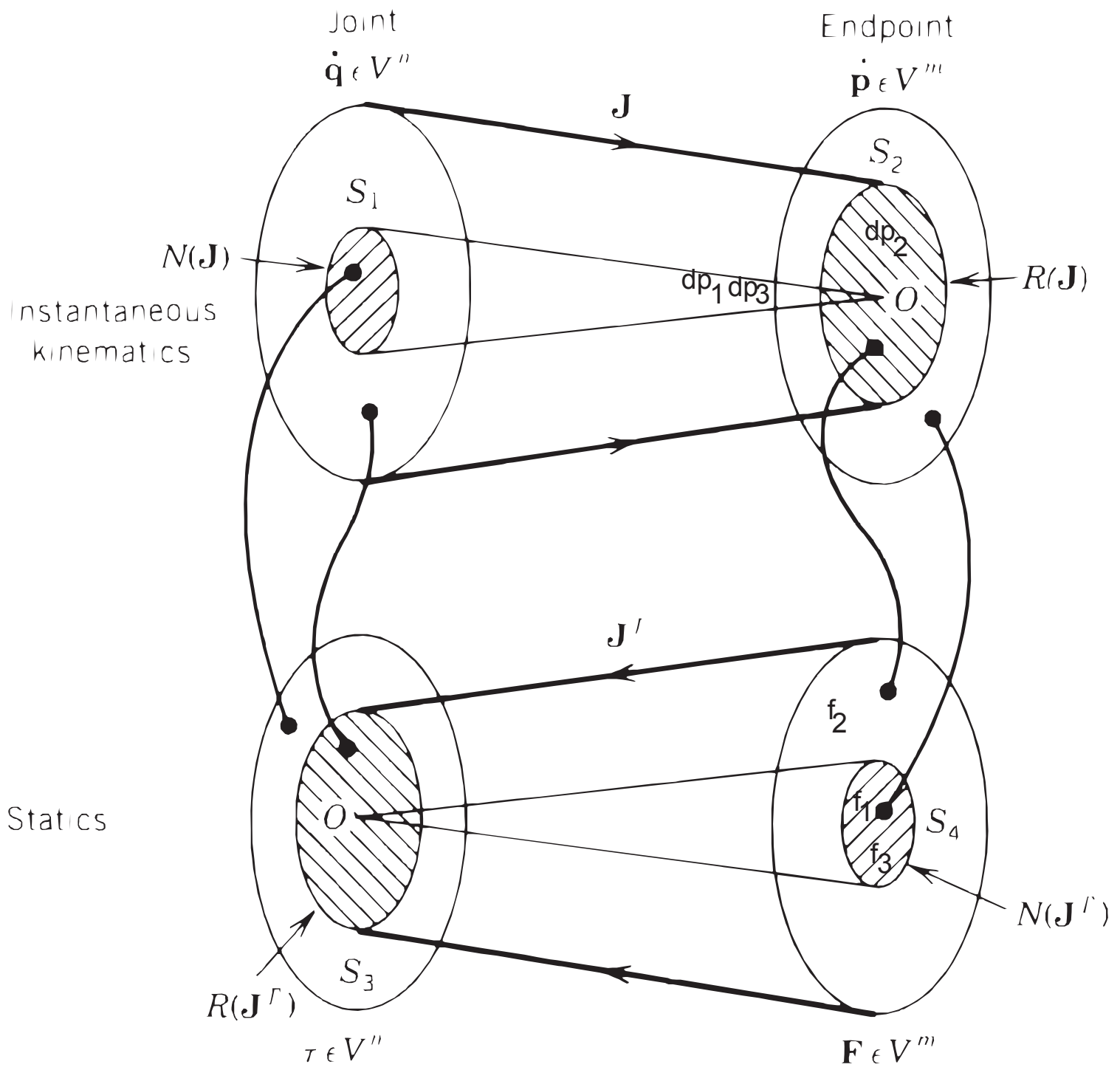

1

2

3

4

5

6

7

8

9

10

11

12

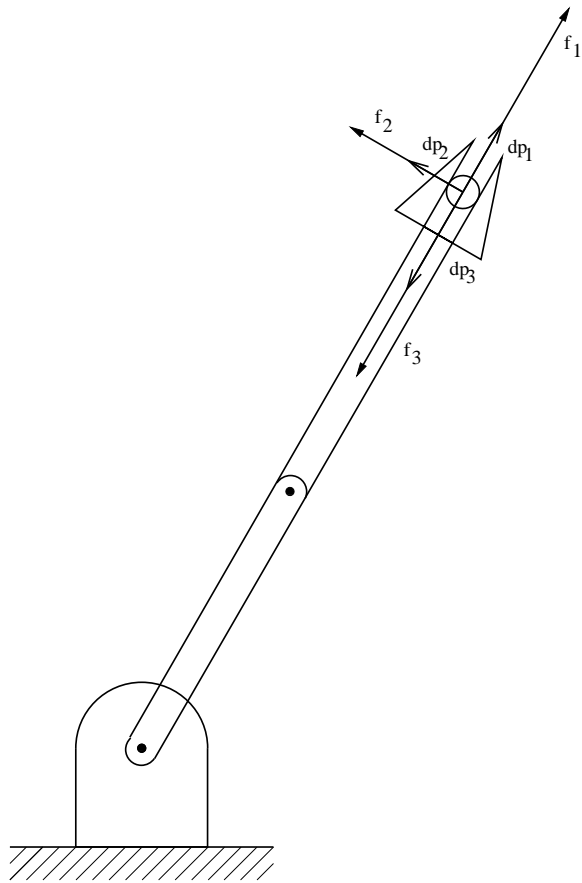

1
2
3
4
5
6
7
8
9
10
11
12

Statics – Example

